

- NOTES:**
1. THE CONTRACTOR SHALL HAVE BACKFILLED, COMPACTED, AND PROPERLY PAVED AND ROLLED UP TO FINAL GRADE WITHIN THE OPEN CUT AREA PRIOR TO MILLING OF THE FINAL PATCH.
 2. IF BINDER COURSE IS LEFT EXPOSED OVER WINTER, IT SHALL BE KEYED INTO THE EXISTING PAVEMENT WITH A 3" RECESS. FOR GUIDANCE ON SUB SURFACE WORK, REFER TO M.C.D.O.T. DETAIL TITLED "TRENCH AND PAVEMENT RESTORATION FOR ROAD CUT".
 3. JOINTS SHALL BE SAWCUT AND TACK COAT APPLIED PRIOR TO FINAL PAVING. AFTER FINAL PAVING THE JOINTS SHALL BE SEALED WITH FIBER CRACKFILL.

ASPHALT PATCH OVER FULL DEPTH TRENCH REPLACEMENT
NOT TO SCALE - REVISED: 06/12/23

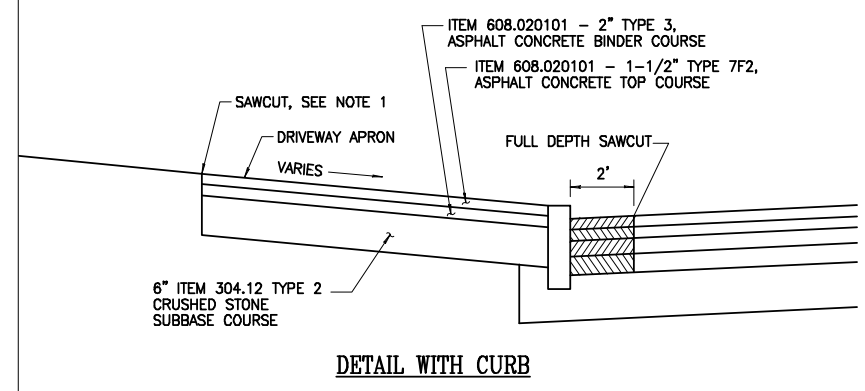
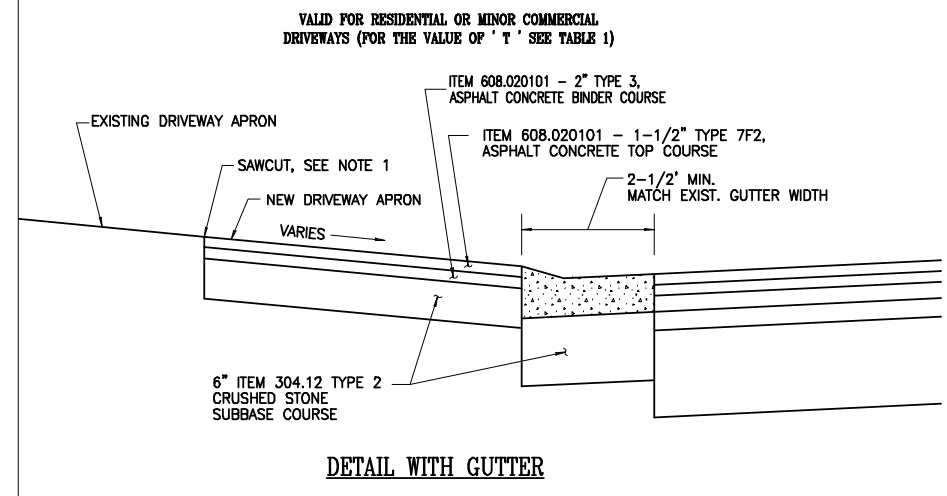

- NOTES:**
1. ALL PAVEMENT JOINTS SHALL BE SAWCUT AND TACK COATED.
 2. TOPSOIL AND SEED ALL DISTURBED AREAS WITH TOPSOIL ITEM NO. 613.0101 AND SEED ITEM NO. 610.0203.

ASPHALT DRIVEWAY DETAILS
NOT TO SCALE - REVISED: 06/12/23

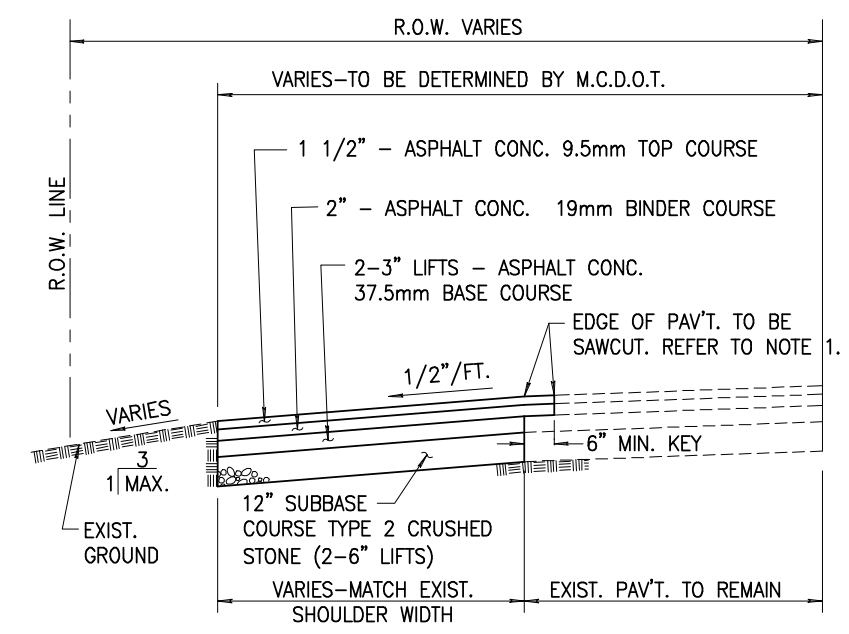

- NOTES:**
1. EXISTING ASPHALT SHOULDER SHALL BE SAWCUT PRIOR TO PERFORMING ANY EXCAVATION WITHIN THE SHOULDER. ALL PAVEMENT JOINTS SHALL BE TACK COATED AND SEALED WITH BITUMINOUS SEALER.
 2. LOCATION OF THE SAWCUT IS TO BE DETERMINED IN THE FIELD AND TO BE GOVERNED BY EXISTING CRACKS IN THE ROAD.
 3. IF A ROADSIDE DITCH EXISTS, THE STONE SUBBASE MUST BE EXTENDED TO THE DITCH.
 4. REPLACE SHOULDER PAVEMENT SECTION IN KIND WITH WHAT IS EXISTING, UNLESS CONDITIONS EXIST WHERE THAT ISN'T FEASIBLE OR IF NEW, THEN INSTALL SECTION AS APPROVED BY THE DEPARTMENT'S ENGINEER OR HIGHWAY MAINTENANCE MANAGER. THE MINIMUM APPROVABLE SECTION SHALL BE 6" OF TYPE 2 SUBBASE (CRUSHER RUN STONE), 2" OF ASPHALT CONC. 19mm BINDER COURSE AND 1 1/2" OF ASPHALT CONC. 9.5mm TOP COURSE.

ASPHALT SHOULDER - NEW OR REPLACEMENT
NOT TO SCALE - REVISED: 06/12/23

NO.	DATE	BY:	REVISION

CONSULTANT
 Consultant Address: (565) 867-5309
 Rochester, New York XXXX
 Fax: (565) 867-5309

PROJECT MANAGER: _____
 MANAGER

DRAWN BY: _____
 DRAFTER

DEPARTMENT OF TRANSPORTATION
 50 WEST MAIN STREET, SUITE 6100
 ROCHESTER, NEW YORK 14614-1231
 UNAUTHORIZED ALTERATION OR ADDITION TO THIS DRAWING
 VIOLATES NEW YORK STATE EDUCATION LAW
 ARTICLE 145, SECTION 2207

COUNTY ROAD #	
PROJECT NAME	
PROJECT LIMITS	
TOWN	
CAPITAL PROJECT NO.	XXXX-XX